

Breadboard Traffic Light System

Alex Sawicki & Geoff Yeung

TEJ4M

Mr. Bawa

June20, 2013

Table of Contents

Materials	3
Background Research	4
Experimental Procedure	7
Method One	8
Method Two	9
Conclusions and Future Project Ideas	12
Bibliography	13

Materials

Method One

- 1x 7493 IC
- 1x 7402 IC
- 555 timer IC
- 1x Red LED
- 1x Green LED
- 2x Amber LED
- 1M preset, horizontal
- 5x 220 ohm resistors
- 2.2 μ F 16V radial capacitor
- Coloured Wires

Method Two

- 3x 470 ohm resistors
- 22k ohm resistor
- 100k ohm resistor
- 0.1 μ F capacitor
- 1 μ F 16V radial capacitor
- 10 μ F 16V radial capacitor
- 6x 1N4148 diodes
- 1x Red, Amber, and Green LED
- 1M preset, horizontal
- 555 timer IC
- 4017 counter IC
- On/off switch
- 9V battery
- Coloured Wires

Background Research

555 Timer



The 555 timer is an integrated circuit (IC) is used for timing and acts as a counter. When the 555 timer is activated by current entering in through the second pin, it begins to count for a certain amount of timer. When the timer has finished counting, it emits current from the third pin.

http://www.technologystudent.com/elec_flash/timer1a.htm

http://www.cci-compeng.com/Unit_2_Electronics/2308_555_Timer.htm

7493 IC



The 7493 integrated circuit is an up-counter which is capable of operating as a multi-modulus counter. The IC is constructed of two negative-edge triggered counters that in their natural state are a mod 2 and mod 8 up counter. The mod-2 or binary counter changes its count every time a negative pulse is applied to the input.

<http://www.wisc-online.com/Objects/ViewObject.aspx?ID=DIG5403>

4017 counter IC



The 4017 decade counter has ten output pins which go high in sequence when a source of pulses is connected to the input and when the suited logic levels are applied to the enable and reset input pins. Only an individual output is high at any given time.

<http://www.doctrionics.co.uk/4017.htm>

1M preset, horizontal



The 1M horizontal preset changes the resistance in a circuit. Light and temperature sensors have preset resistors, which allow the circuit to be made more or less sensitive. The range of the resistance is 0 to 1M ohms.

<http://www.technologystudent.com/elec1/preset1.htm>

Breadboard Traffic Light System

http://electronicsclub.info/p_trafficlight.htm

Experimental Procedure

We first built our 555 timer schematic on our breadboard. We used this knowledge of 555 timers to experiment different routes we could take in order to model an operational traffic light system.

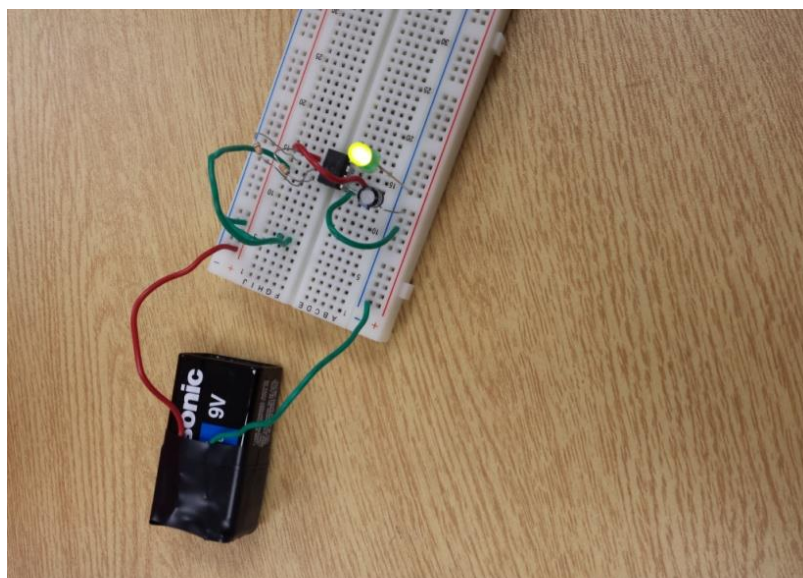

Circuit with 555 timer

We then came to the conclusion that we needed more materials than 555 timers and different resistance values to successfully model a traffic light system.

The 4017 IC chip caught our eye as it allowed us to work in combination with the 555 timer to come up with our best model. It is also designed to drive higher current loads so there is no harm in connecting series resistors directly to its outputs, allowing for simpler design, and so that there is no worry of too much current going through it.

We also had a backup in case the 4017 chip did not work. This was to use the 7493 IC chip and a 7402 IC chip in combination with a 555 timer to produce a slightly differently operating traffic light system.

Method One

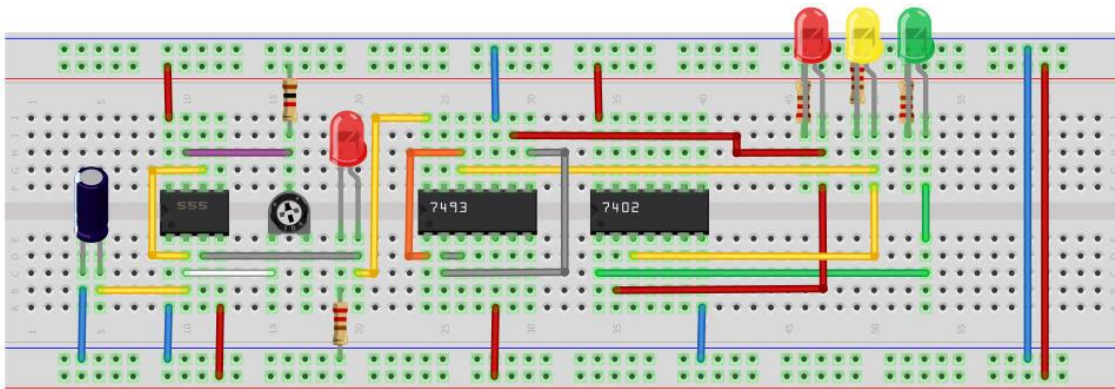

Diagram of method one, using the 7493 and 7402 IC

The first method used to create a breadboard traffic light system was to use the 555 timer, combined with the 7402 and 7493 IC. The 555 timer controls the current in randomly timed intervals. The 7493 IC determines the output, and depending on the pin will light up with the corresponding LED, but only one at a time. The 1M preset controls the resistance. The 1M preset changes the resistance in our breadboard, so that the LEDs do not burn from too extreme amounts of voltage.

The second method designed to create a breadboard traffic light system was to use the 555 timer, combined with the 4017 IC counter. First, the circuit contains a switch. This switch turns on and off the circuit, enabling and disabling the voltage/current flow. The circuit then contains the aforementioned 555 timer and the 4017 IC counter. The 555 timer is used as a counter so that the 4017 IC counter has a controlled amount of current for the LEDs.

The 4017 IC counter is used to control flow so that only one LED lights up at a time. According to our background research, this should hold true because only one pin on the 4017 IC counter has a high output at a time, therefore, only one LED will light up at a time as well. Since the high output pin switches at random times, due to the 555 timer, as one LED turns off, another LED will simultaneously turn on. For example, if the red LED were to turn on first, this means the pin which the red LED is connected to should be high. At the exact same time, the amber and the green LEDs are off. This is because only one pin is high at a time. As the red light turns off, the green light will turn on at the same time.

Similar to the first method, the 1M preset determines the resistance and allows the correct amount of current flow.

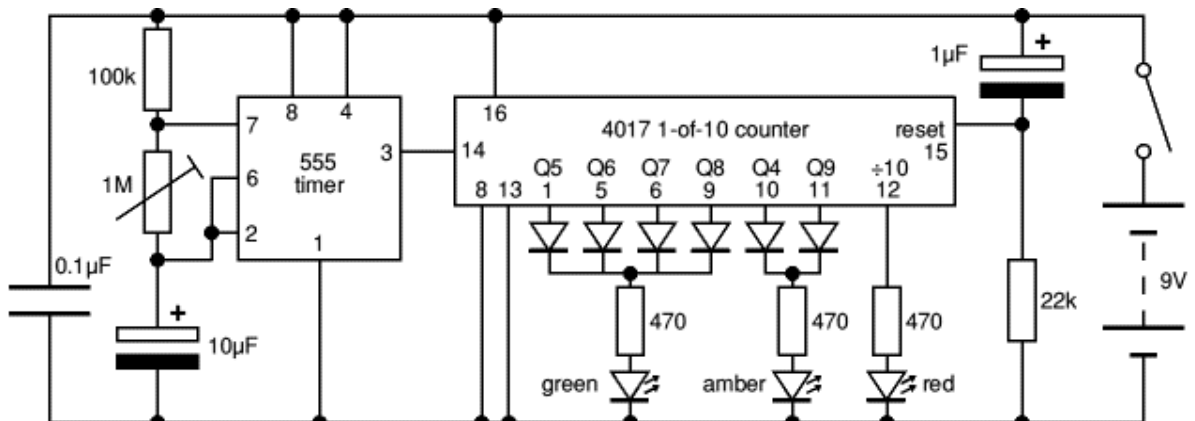

Circuit diagram of method two

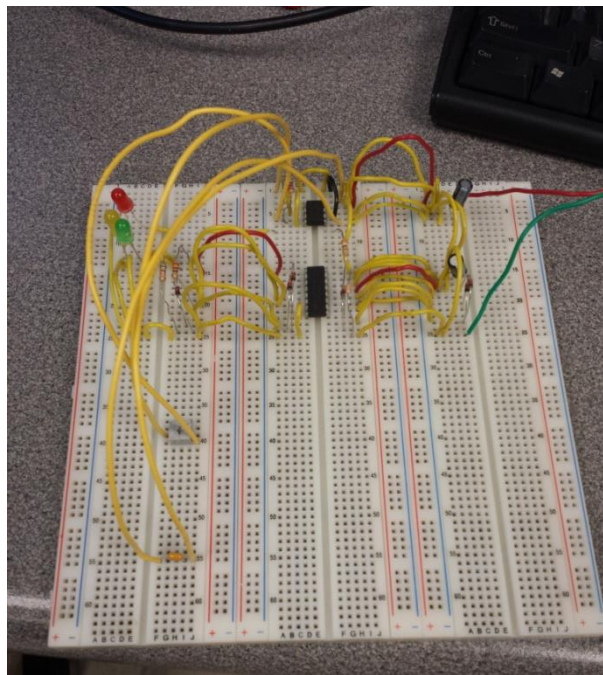

Attempted circuit of method two

The image above is the first attempt at using the 555 timer and the 4017 IC. The first attempt of the 4017 IC and 555 timer circuit also did not work. Changes in both wiring and resistance were issued, but no output occurred. None of the LEDs lit up after both processes.

We also attempted to use some of the backup breadboards, thinking that the issue was that a breadboard may be faulty, but this once again, did not resolve the issue.

Conclusions and Future Project Ideas

For this project we had a main and primary plan that we chose to follow to complete our traffic light project which included a 555 timer and a 4017 IC chip. We then also had a secondary plan to see which method would work better. This secondary layout included a 555 timer, a 7493 IC chip and a 7402 IC chip. Through extensive testing and multiple attempts at problem solving, we could not get any of the layout to properly work as they should have. Even when we referenced several different resources, the layouts did not operate as they were intended to.

Arduino Board

An Arduino board is an open source electronics platform based on flexible, simple user friendly hardware and software. The Arduino board makes the process of using electronics in multidisciplinary projects more accessible. The board could aid in making the breadboard traffic light system with its ability to be programmed. The LEDs could be programmed so that only one will light up at a time in the correct sequence, for a determined time interval.

<http://arduino.cc/en/Tutorial/AnalogWriteMega>

This is an example of a circuit provided by the original website. This example fades 12 LEDs up and down, one at a time in sequence, using the Arduino Mega board. It also provides the code necessary to time the pin for a certain length of time, to have a high output and to delay it by 2

milliseconds, which can be changed. The board would make the timing of the LEDs much easier, and therefore, would be programmable to allow the bulbs to light up for the correct length of time as a real traffic light would occur, rather than randomly determined when using the 555 timer.

Simplification

With all electronics, there is always a method of simplification and elimination. The circuits researched could always be simplified so that fewer parts are required, and that it can run more smoothly. If this were to occur, building a traffic light system on a breadboard would be quicker to complete and more cost effective.

Bibliography

John, Hewes. "Traffic Light Project." Traffic Light Project. Electronicsclub, 2013. Web. 20 June 2013.

Ryan, V. "A Design and Technology Site." A Design and Technology Site. Technology Student, 2012. Web. 20 June 2013.

Phillips, W D. "Doctrionics." 4017 Decade Counter. Doctrionics Educational Publishing, 1 Aug. 2008. Web. 20 June 2013.